

MAXIM

MAX4135 Evaluation Kit

General Description

The MAX4135 evaluation kit (EV kit) simplifies evaluation of the MAX4135 one-input, six-output distribution amplifier. The EV kit circuit demonstrates the MAX4135 in a fixed gain of 2V/V. RF-style connectors (SMA) and 75Ω terminating resistors are included for video test-equipment compatibility.

The EV kit comes with the MAX4135 installed, but can also be used to evaluate the MAX4136, MAX4137, and MAX4138 video distribution amplifiers. Contact Maxim to order free samples.

Ordering Information

PART	TEMP RANGE	BOARD TYPE
MAX4135EVKIT-SO	+25°C	Surface Mount

Note: Request free samples to evaluate the MAX4136EWG, MAX4137EWG, or MAX4138EWG.

Component List

DESIGNATION	QTY	DESCRIPTION
C2, C4, C5, C6	4	0.1μF, 10% ceramic capacitors Vitramon VJ1206Y104KXX
C1, C3	2	10μF, 10V, 20% tantalum capacitors AVX TAJB106M010 Sprague 293D106X0010B
IN, OUT1–OUT6	7	SMA connectors
R1, R2, R3, R4, R5, R6, R7	7	75Ω, 5% resistors
R8–R13	6	100kΩ, 5% resistors
RG	1	0Ω resistor
SW1	1	DIP switch
U1	1	MAX4135EWG
None	1	MAX4135 PC board
None	1	MAX4135/MAX4136 data sheet

Component Suppliers

SUPPLIER	PHONE	FAX
AVX	803-946-0690	803-626-3123
Sprague	603-224-1961	603-224-1430
Vishay/Vitramon	203-268-6261	203-452-5670

Features

- ◆ 185MHz -3dB Bandwidth
- ◆ Outputs Can Be Independently Enabled and Disabled
- ◆ Fully Assembled and Tested

Quick Start

The MAX4135 EV kit is fully assembled and tested. Follow these steps to verify board operation. **Do not turn on the power supply until all connections are completed.**

- 1) The circuit requires supply voltages of ±5V. Connect a +5V supply to the pad marked VCC. Connect a -5V supply to the pad marked VEE. Connect the power-supply ground to the pad marked GND.
- 2) Apply a signal in the +1.1V to -1.0V range to the SMA connector marked IN.
- 3) Connect the output marked OUT1 to an oscilloscope through a terminated 75Ω cable.
- 4) On DIP switch SW1, set the $\overline{\text{SEL1}}$ switch to the on position. Set all other switches to off.
- 5) Turn on the power supply and verify the output signal on the oscilloscope.

Detailed Description

Output Channel Selection

The MAX4135 provides TTL/CMOS-compatible, digital control pins (SEL1–SEL6) to enable or disable each amplifier output. When the SEL_n input is low, the amplifier is enabled; when it is high, the amplifier is disabled.

The EV kit uses a DIP switch (SW1) to manually enable/disable outputs. When a switch is on, the SEL_n pin is connected to ground, and the corresponding amplifier is enabled. When a switch is off, the SEL_n pin is connected to +5V through a 100kΩ pull-up resistor, and the corresponding amplifier is disabled.

To use an external controller, set the desired SEL_n switch(es) to on and connect the external controller to the pad(s) labeled SEL_n.

Evaluates: MAX4135/MAX4136/MAX4137/MAX4138

MAX4135 Evaluation Kit

MAX4136, MAX4137, MAX4138 Configuration

The MAX4135 EV kit can easily be configured to evaluate the MAX4136, MAX4137, or MAX4138. The primary differences between the four parts are the number of output channels (four or six), and either fixed (2V/V) or adjustable gain (≥ 2 V/V). Refer to Table 1 and to the MAX4135/MAX4136 and MAX4137/MAX4138 data sheets for further information.

Evaluating the MAX4136

To evaluate the MAX4136, simply order a free sample (MAX4136EWG), replace the MAX4135 with the MAX4136 on the PC board, and select and install the gain-setting resistors for the desired gain.

Evaluating the MAX4137

To evaluate the MAX4137, order a free sample (MAX4137EWG) and replace the MAX4135 with the MAX4137 on the PC board. Keep the 0Ω resistor in RG and leave RF open. Note that the four output channels correspond to those labeled OUT2–OUT5, and are selected via SEL2–SEL5 on SW1 (see Table 2).

Evaluating the MAX4138

To evaluate the MAX4138, simply order a free sample (MAX4138EWG), replace the MAX4135 with the MAX4138 on the PC board, and select and install the gain-setting resistors for the desired gain. Note that the four output channels correspond to those labeled OUT2–OUT5, and are selected via SEL2–SEL5 on SW1 (see Table 2).

Table 1. Gain Configuration

PART	No. OF OUTPUTS	GAIN V/V	RF	RG
MAX4135	6	Fixed at 2	Open	0Ω
MAX4136	6	≥ 2	User selected	User selected
MAX4137	4	Fixed at 2	Open	0Ω
MAX4138	4	≥ 2	User selected	User selected

Layout Considerations

The MAX4135 EV kit layout has been optimized for high-speed signals and low distortion, with careful attention given to grounding, power-supply bypassing, and signal-path layout. The small, surface-mount, ceramic bypass capacitors (C2, C4, C5, and C6) have been placed as close to the four MAX4135 supply pins as possible. The ground plane has been removed around and under the MAX4135 to reduce stray capacitance. The removal of ground plane around the input SMA connector reduces distortion.

Table 2. Output Channel Selection

PART	No. OF OUTPUTS	SW1 SWITCH SETTINGS					
		SEL1	SEL2	SEL3	SEL4	SEL5	SEL6
MAX4135	6	OUT1	OUT2	OUT3	OUT4	OUT5	OUT6
MAX4136	6	OUT1	OUT2	OUT3	OUT4	OUT5	OUT6
MAX4137	4	—	OUT1	OUT2	OUT3	OUT4	—
MAX4138	4	—	OUT1	OUT2	OUT3	OUT4	—

MAX4135 Evaluation Kit

Evaluates: MAX4135/MAX4136/MAX4137/MAX4138

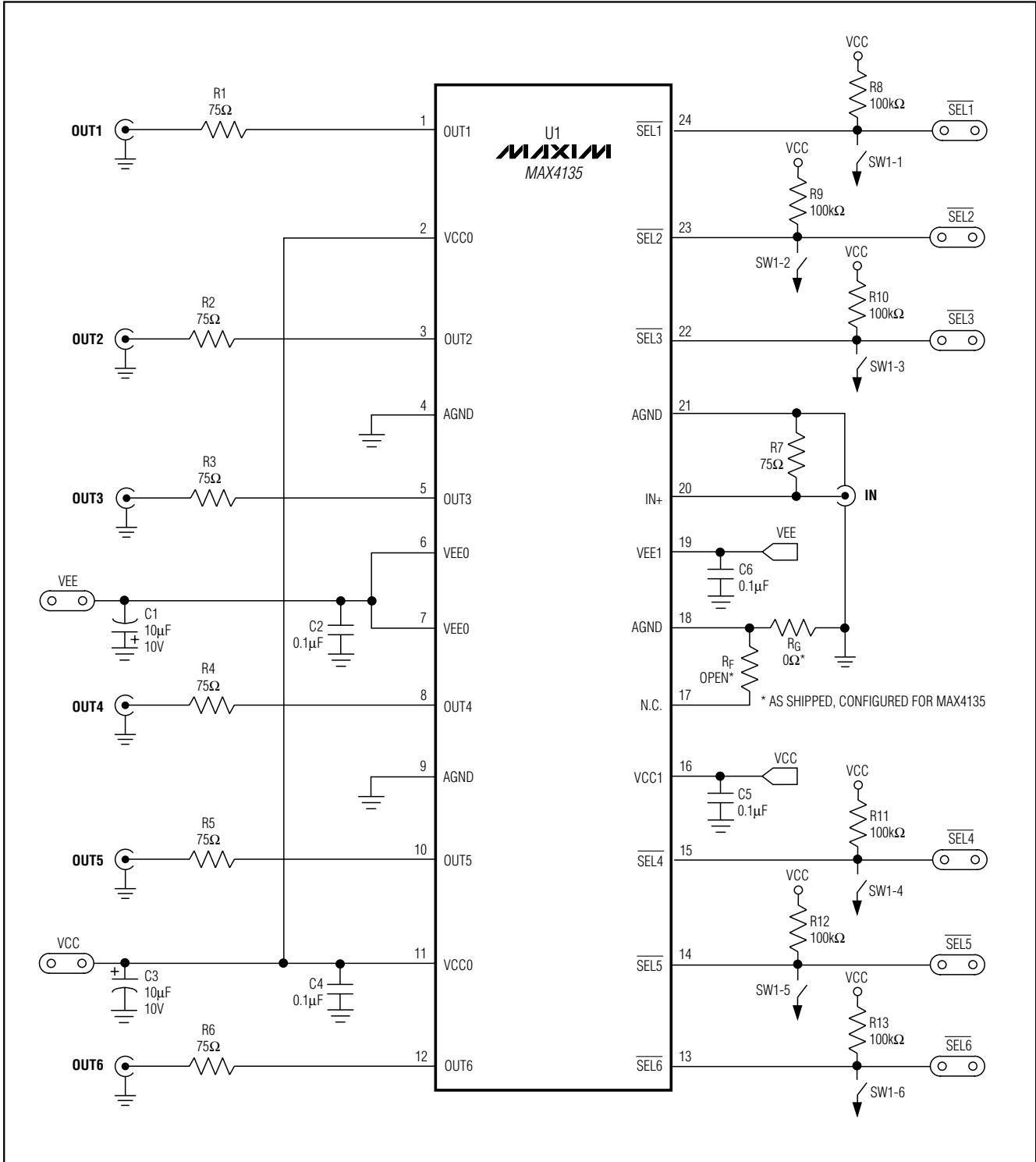

Figure 1. MAX4135 EV Kit Schematic

MAX4135 Evaluation Kit

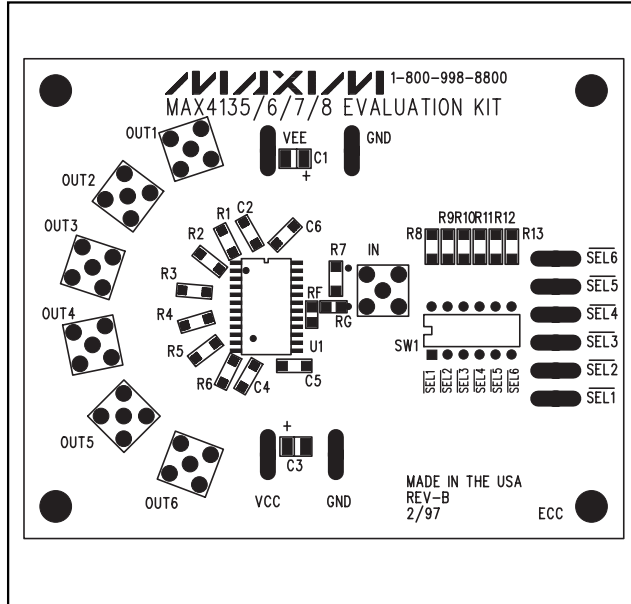

Figure 2. MAX4135 EV Kit Component Placement Guide—Component Side

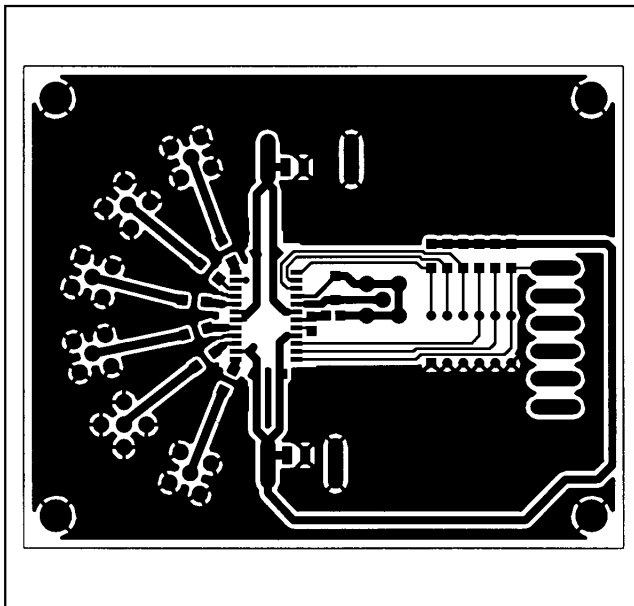

Figure 3. MAX4135 EV Kit PC Board Layout—Component Side

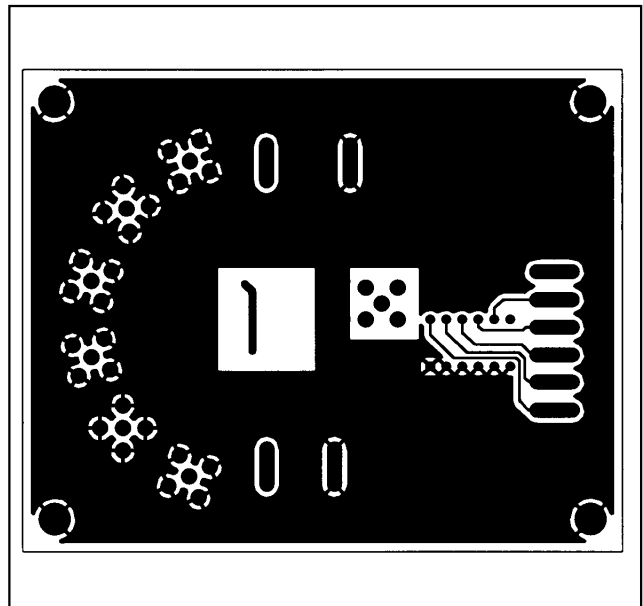

Figure 4. MAX4135 EV Kit PC Board Layout—Solder Side

Maxim cannot assume responsibility for use of any circuitry other than circuitry entirely embodied in a Maxim product. No circuit patent licenses are implied. Maxim reserves the right to change the circuitry and specifications without notice at any time.

4 _____ **Maxim Integrated Products, 120 San Gabriel Drive, Sunnyvale, CA 94086 (408) 737-7600**